



# ECTRA-SHIFT



## INSTALLATION INSTRUCTIONS

# INTRODUCING THE



The Muncie Lectra shift is designed for use on most heavy duty trucks with a 12V negative ground system. The engagement of the PTO requires a substantial amount of current but only a small amount of current to maintain engagement.

The Lectra Shift engagement is controlled by the operator. It is the operator who must ensure that the transmission PTO drive gear is stopped. Refer to the PTO Owner's Manual for engagement and disengagement procedures. This manual (IN84-03) is provided with every PTO. The Lectra Shift system requires the operator to press a rocker switch to engage the PTO. Releasing the rocker switch places the PTO into the active mode and the PTO is held in gear electronically. This activation can be observed by the indicator light provided with this system. If the PTO does not engage immediately then the operator should turn the PTO OFF and reactivate it through the same procedures. The Operator should avoid holding in on the rocker switch for more than 3-4 seconds to prevent overheating of the system.

Because of the varying current requirements, it is essential that the Lectra Shift unit be connected as shown in the drawing provided. Do not alter the harness or make additional connections without the approval of Muncie Power Products.

If you did not receive the PTO Owner's Manual or the packet containing warning labels, or if you need extra, you can obtain these, at no charge, by phone or mail. They are available through your nearest Muncie distributor or at the number and address below:

1-800-FOR-PTOS (367-7867)  
Customer Service Department  
Muncie Power Products, Inc.  
P. O. Box 548  
Muncie, IN 47308-0548

# ASSEMBLY COMPONENTS

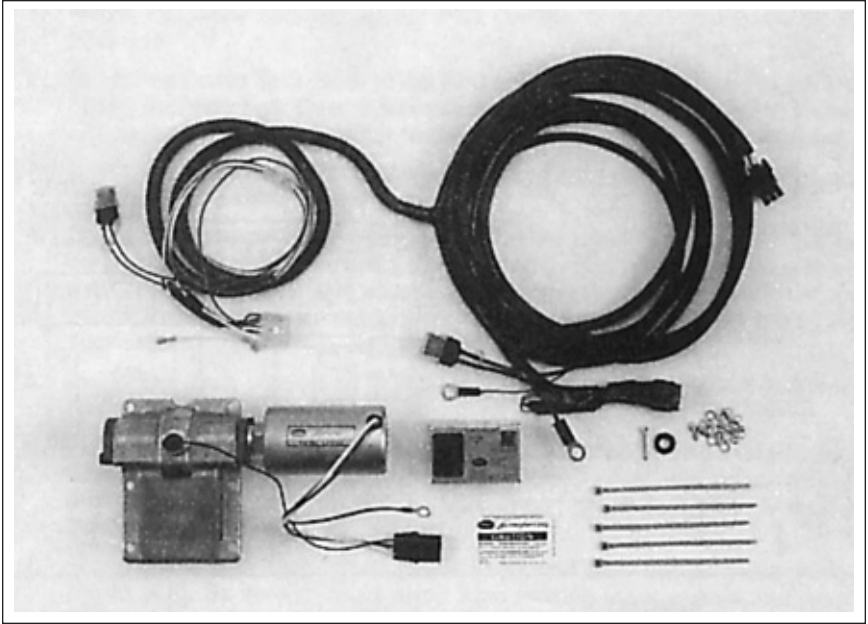

## TOOLS NEEDED:

The Lectra Shift does not require any special tools for installation. Most mechanics will have the required tools to install the Lectra Shift cover and to mount all the electrical components. Tools needed include:

- Assorted Wrenches
- Power Drill & Bits
- Cable Ties &/or Wire Loom
- Nut Drivers
- Wire Stripper & Crimper (optional)
- Dielectric Grease

# WIRING DIAGRAM

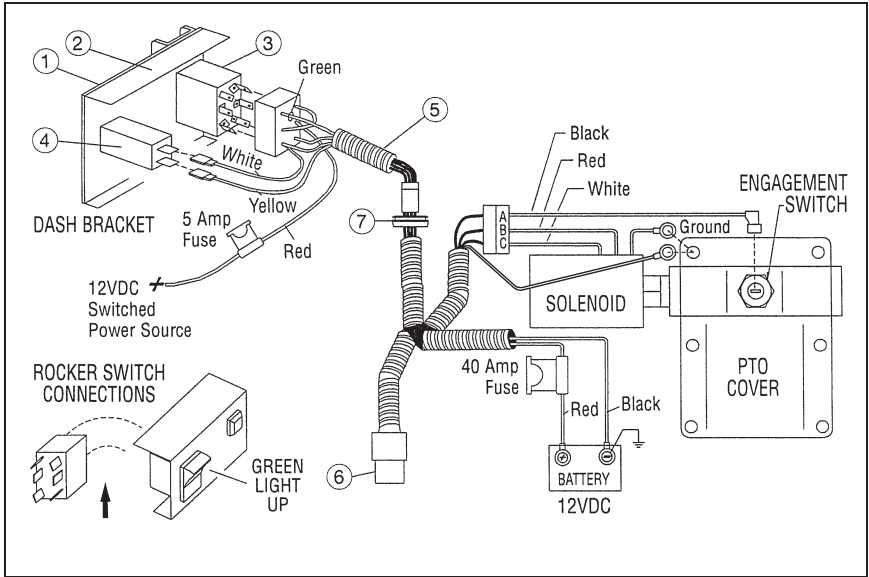

## INSTALLATION KIT NUMBER (INCLUDES ALL PARTS BELOW)

**48TK3981**

ITEM	QTY	PART NUMBER	DESCRIPTION
1	1	36T35431	Face Plate
2	1	36MA1005	Dash Bracket
3	1	30T37620	Switch
4	1	32MSR12V	Light 12VDC
5	1	34T37751	Wire Harness
6*	1	37T37621	Relay
7	1	37T35674	Grommet
8	1	19T35439	Sheet Metal Screw
NS	5	28T35442	Wire Tie
NS	1	36MK1007	Bolt Kit
NS	1	36T35710	Dash Label (MC92-01)
NS	1	36T39187	Dash Label

Indicator switch sold separately—Not included in above installation kit.

Replacement fuses sold as service items: 5 Amp – 33T37923

40 Amp – 33T36951

\* Relay is supplied in the wire harness.

### Conversion Kit Numbers—Wire To Lectra Shift

**16MK3848A (1 & 4 Assy.)**

**16MK3849A (2 & 3 Assy.)**

# LECTRA SHIFT INSTALLATION INSTRUCTIONS

1. Install the power take-off per the PTO Owner's Manual enclosed with the PTO unit.
2. Mount the Lectra Shift cover to the PTO and ground the solenoid to the shift cover mounting bolt. Coat this connection with a suitable dielectric grease. Connect the booted connector to the indicator switch on PTO shift cover.
3. Locate a suitable location in the engine compartment for the relay (6) and mount with sheet metal screw provided.
4. Drill a 5/8" hole or find a pass-thru in the fire wall which the 3/8" square connector of the wire harness (5) can be fed through to the cab. The grommet (7) is provided for this pass-thru. Separate the square connector and pass it through the grommet to the inside of the cab. Reconnect the square connector.
5. Mount the dash bracket (2) in the cab either under the dash or within the dash area.
6. Plug in the molded connector to the back of switch per the 48TK3981 wiring diagram. The green wire in back of connector is up. Connect the power wire to a 12V keyed accessory power source. Modification of wire harness is NOT recommended. Notify Customer Service if modifications are required.
7. Route the 3-wire plug down to the PTO and connect to the solenoid 3-wire plug. Be sure to route away from moving components and manifold and exhaust components and cable tie into position or protect in your typical method. There is a 10ga black wire that is to be connected to the PTO shift cover.
8. Attach the 10ga red wire from the wire harness directly to the positive battery terminal or a direct battery connection terminal. Connect the double black wire to the negative terminal. Coat connections with a suitable dielectric grease. This wire may be shortened, but do not make it any longer than supplied.
9. Be sure all wires are tied out of the way of moving components and the heat of the manifold or exhaust systems. Protect wire from wear at pass-thru points with wire looms or grommets (not supplied). Place label #36T35710 and #36T39187 (supplied with this kit) on the dash near the PTO rocker switch. The label provided with the PTO, #36M35652 is not used and can be discarded.
10. Refill the transmission with the proper oil. If the solenoid has to be removed to refill the transmission then re-torque the solenoid to 107 ft.lbs. Loctite Thread Locker 242™ should be used on solenoid threads should it be removed.

**Note: Do not use a Muncie Electronic Overspeed Switch (SPD-1001A) with this product. The Lectra Shift option requires that the transmission drive gear be stopped prior to PTO engagement or disengagement.**

# PARTS LIST AND DESCRIPTION

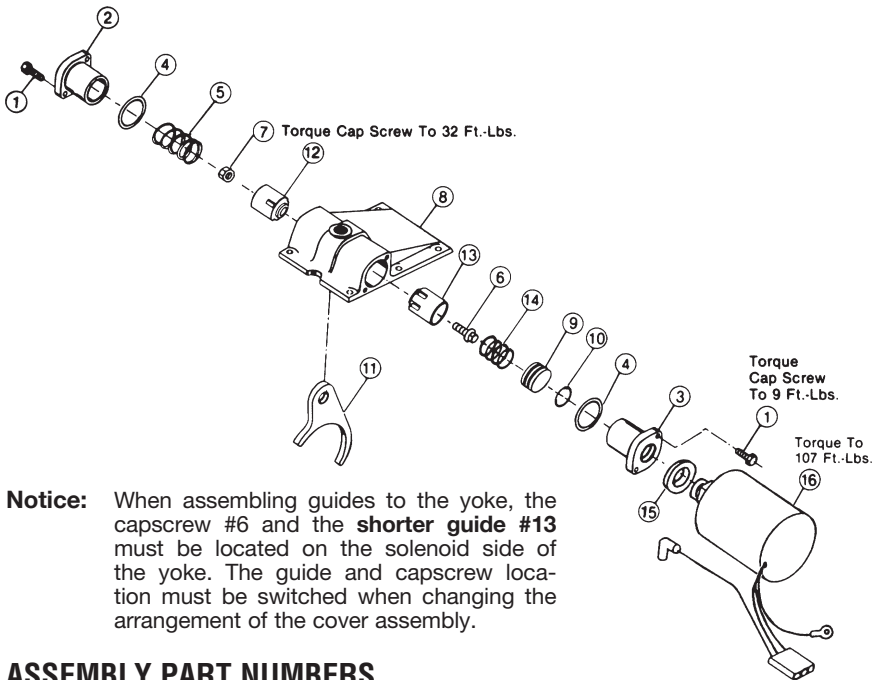

**Notice:** When assembling guides to the yoke, the cap screw #6 and the **shorter guide #13** must be located on the solenoid side of the yoke. The guide and cap screw location must be switched when changing the arrangement of the cover assembly.

## ASSEMBLY PART NUMBERS

**16TA3822A** For Assemblies 1 & 4 (Assembly Shown)

**16TA3823A** For Assemblies 2 & 3

ITEM	QTY	PART NUMBER	DESCRIPTION
1	4	19T34494	Capscrew
2	1	28T35675	Cover Cup, Spring End
3	1	28T35387	Cover Cup, Solenoid
4	2	13T38286	Gasket
5	1	27T35073	Spring (Long)
6	1	19T35680	Capscrew
7	1	22T35683	Locknut
8	1	16T35377	Cover Housing
9	1	49T35389	Piston
10	1	12T35304	O-Ring
11	1	28T34481	Yoke
12	1	28T35695	Guide (Long)
13	1	28T35390	Guide (Short)
14	1	27T35391	Spring (Short)
15	1	28T35392	Spacer
16	1	28T38201	Solenoid *

**TG-SSSK** Lectra Shift Seal Kit – Includes Items 4, 10 and 13T34279, 12M01014

\* If wire harness does not have separate groundwire, then one needs to be added or purchase latest revision of wire harness.

# TROUBLESHOOTING

PROBLEM	CAUSE	REMEDY
<b>PTO WON'T ENGAGE</b>	Mechanical: Improper Shifting – Shift collar has burrs which won't allow fork to shift – Fork is not assembled into shift collar	– Dismantle PTO and remove burrs – Remove cover and reposition properly
	Electrical: – Loose wire or connection – Solenoid overheated – Improperly wired – Blown fuse	– Correct as necessary – Allow to cool – Double check with schematic – Check wiring, replace fuse
<b>PTO WON'T DISENGAGE</b>	– Improper shifting, shift collar has burrs which won't allow fork to shift	– Dismantle PTO and remove burrs
<b>WIRES GET HOT</b>	– Short circuit – Shifter not installed correctly to PTO	– Check installation – Remove cover, check assembly per parts list and reinstall, making sure fork is properly located in collar
<b>PTO WON'T STAY ENGAGED</b>	– PTO not fully engaged – Other components wired into circuit – Faulty module or solenoid	– Turn off PTO and retry engagement – Remove accessory components and rewire into their own circuit – Test and replace

## SOLENOID TEST:

Resistance – Hold Coil – Red Wire = 5.9 Ohm

Resistance – Engage Coil – White Wire = 0.3 Ohm

*Values checked at room temperature (approx. 72°F)*

## POWER TAKE OFF WARRANTY

The Muncie Power Take-Off is warranted to be free of defects in material or workmanship and to meet Muncie's standard written specifications at the time of sale. Muncie's obligation and liability under this warranty is expressly limited to repairing or replacing, at Muncie's option, within two years after date of original installation any defective part or parts or any product not meeting the specifications.

**THIS WARRANTY IS IN LIEU OF ALL OTHER WARRANTIES, EXPRESSED OR IMPLIED. MUNCIE MAKES NO WARRANTY OF MERCHANTABILITY OR OF FITNESS FOR ANY PARTICULAR PURPOSE. MUNCIE'S OBLIGATION UNDER THIS WARRANTY SHALL NOT INCLUDE ANY TRANSPORTATION CHARGES OR COSTS OF INSTALLATION OR ANY LIABILITY FOR DIRECT, INDIRECT SPECIAL, INCIDENTAL, OR CONSEQUENTIAL DAMAGES OR DELAY. THE REMEDIES SET FORTH HEREIN ARE EXCLUSIVE, AND MUNCIE'S LIABILITY WITH RESPECT TO ANY CONTRACT OR SALE OR ANYTHING DONE IN CONNECTION THEREWITH, WHETHER IN CONTRACT, IN TORT, UNDER ANY WARRANTY, OR OTHERWISE, SHALL NOT, EXCEPT AS EXPRESSLY PROVIDED HEREIN, EXCEED THE PRICE OF THE PRODUCT OR PART ON WHICH SUCH LIABILITY IS BASED.**

If requested by Muncie, products or parts for which a warranty claim is made are to be returned transportation prepaid to a Muncie Service Center. Any installation or use not in accordance with catalogue or package instructions, other improper use, operation beyond capacity, substitution of parts not approved by Muncie, use with equipment other than the equipment on which the Power Take-Off is first installed, or alteration or repair made to the Power Take-Off other than at a Muncie Service Center shall void this warranty. No employee or representative of Muncie is authorized to change this warranty in any way or to grant any other warranty.



**Muncie®  
Power  
Products**



**Muncie Power Products, Inc.** *Member of the Interpump Hydraulics Group*  
General Offices and Distribution Center • P.O. Box 548 • Muncie, IN 47308-0548 • (765) 284-7721  
FAX (765) 284-6991 • E-mail [info@munciepower.com](mailto:info@munciepower.com) • Web site <http://www.munciepower.com>  
Drive Products, Exclusive Agents for Canada, ISO Certified by an Accredited Registrar